

Naval Brass Sleeve Bearings

INCH SIZE SERIES



Johnson Cutless® Naval Brass Sleeve Bearings adapt equally well to strut and stern tube mounts, and are often used effectively as rudder-stock and pintle bushings. Bearing diameters are precision fitted to the designated shaft size with the correct clearance for efficient water lubrication. External brass shells are machined and polished to provide easy fitting. Specially formulated oil and chemical resistant nitrile rubber is securely bonded to the shell. Units with thin shells are available for the struts of small craft. Sleeve bearings are usually installed by light press-fitting and locked in place with cone-pointed set screws.

PRECAUTION:

When shrink fitting of the bearing is required, chilling must be achieved by gradual cooling to not more than minus 20°F(-28°C) using freezer or regular ice (**DO NOT DRY ICE**). NOTE: Pounding or shocking the bearing while in the chilled state could cause the rubber to separate from the shell.

Approved Bearings: Johnson Cutless® Naval Brass Sleeve Bearings meet military specification MIL-B-17901 (Ships) Class II Full-Molded type and have full type approval from The American Bureau of Shipping.

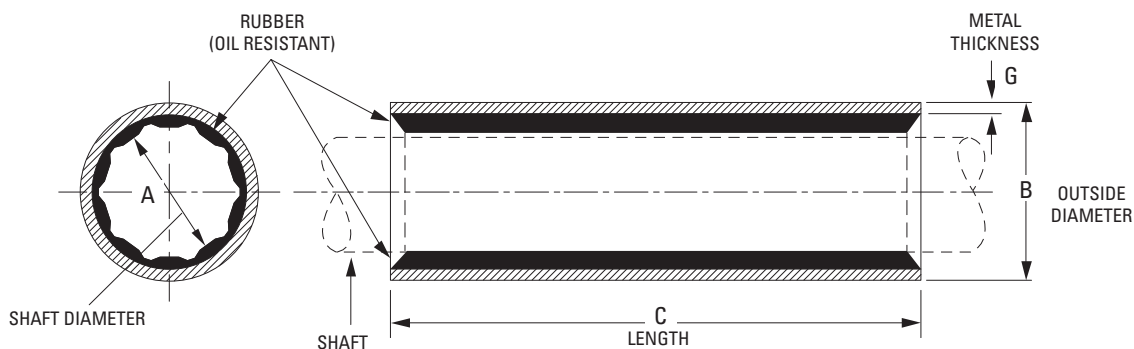

Part Number	Code	A		B		C		G		Gross Wt.	
		Shaft Diameter inches	mm	Outside Diameter inches	mm	Length inches	mm	Metal Thickness inches	mm	lb.	kg.
870192100	ABLE	3/4	19.05	1 1/4	31.75	3	76.20	1/8	3.18	0.5	0.2
870222100	* ACID	7/8	22.23	1 1/4	31.75	3 1/2	88.90	1/16	1.59	0.4	0.2
870222101	APEX	7/8	22.23	1 3/8	34.93	3 1/2	88.90	1/8	3.18	0.7	0.3
870222102	ATOM	7/8	22.23	1 1/2	38.10	3 1/2	88.90	1/8	3.18	0.8	0.4
870252100	* BACK	1	25.40	1 1/4	31.75	4	101.60	3/64	1.19	0.4	0.2
870252144	* BADE	1	25.40	1 1/4	31.75	6	152.40	1/16	1.59	0.6	0.3
870252101	BAIT	1	25.40	1 3/8	34.93	4	101.60	1/16	1.59	0.5	0.2
870252102	BALE	1	25.40	1 1/2	38.10	4	101.60	1/8	3.18	0.7	0.3
870252103	BAND	1	25.40	1 5/8	41.28	4	101.60	1/8	3.18	0.9	0.4
870252104	BASE	1	25.40	2	50.80	4	101.60	1/8	3.18	1.3	0.6
870292100	* BEAM	1 1/8	28.58	1 1/2	38.10	4 1/2	114.30	1/16	1.59	0.6	0.3
870292101	BELT	1 1/8	28.58	1 5/8	41.28	4 1/2	114.30	1/8	3.18	1.0	0.5
870292102	BEND	1 1/8	28.58	1 3/4	44.45	4 1/2	114.30	1/8	3.18	1.1	0.5
870292103	BILL	1 1/8	28.58	2	50.80	4 1/2	114.30	1/8	3.18	1.4	0.6
870322100	* BIND	1 1/4	31.75	1 1/2	38.10	5	127.00	1/16	1.59	0.6	0.3
870322101	BIRD	1 1/4	31.75	1 3/4	44.45	5	127.00	1/8	3.18	1.2	0.5
870322102	BITE	1 1/4	31.75	2	50.80	5	127.00	1/8	3.18	1.5	0.7
870322103	BLOW	1 1/4	31.75	2 1/8	53.98	5	127.00	1/8	3.18	1.7	0.8
870352100	BOAT	1 3/8	34.93	1 7/8	47.63	5 1/2	139.70	1/8	3.18	1.4	0.6
870352101	BOLD	1 3/8	34.93	2	50.80	5 1/2	139.70	1/8	3.18	1.5	0.7
870352102	BOND	1 3/8	34.93	2 1/8	53.98	5 1/2	139.70	1/8	3.18	1.8	0.8
870352103	BOOT	1 3/8	34.93	2 3/8	60.33	5 1/2	139.70	1/8	3.18	1.8	0.8
870382100	BOSS	1 1/2	38.10	2	50.80	6	152.40	1/8	3.18	1.6	0.7
870382101	BRAD	1 1/2	38.10	2 3/8	60.33	6	152.40	1/8	3.18	2.2	1.0
870412100	BREW	1 5/8	41.28	2 1/8	53.98	6 1/2	165.10	1/8	3.18	2.0	1.9
870412101	BRIM	1 5/8	41.28	2 5/8	66.68	6 1/2	165.10	1/8	3.18	2.6	1.2
870452100	BROW	1 3/4	44.45	2 3/8	60.33	7	177.80	1/8	3.18	2.3	1.0

All Bearings Shown Are Carried in Stock

*Slimline Bearing

Part Number	Code	A Shaft Diameter		B Outside Diameter		C Length		G Metal Thickness		Gross Wt.	
		inches	mm	inches	mm	inches	mm	inches	mm	lb.	kg.
870452101	BUCK	1 3/4	44.45	2 5/8	66.68	7	177.80	1/8	3.18	2.8	1.3
870482100	BULB	1 7/8	47.63	2 5/8	66.68	7 1/2	190.50	1/8	3.18	2.8	1.3
870482101	BULL	1 7/8	47.63	2 15/16	74.61	7 1/2	190.50	3/32	2.38	3.1	1.4
870512100	CALL	2	50.80	2 5/8	66.68	8	203.20	1/8	3.18	2.8	1.3
870512143	CAMP	2	50.80	2 3/4	69.85	8	203.20	1/8	3.18	3.3	1.5
870512101	CALM	2	50.80	3	76.20	8	203.20	1/8	3.18	3.8	1.7
870542100	CAME	2 1/8	53.98	2 15/16	74.61	8 1/2	215.90	1/8	3.18	3.1	1.4
870542101	CAPE	2 1/8	53.98	3 1/8	79.38	8 1/2	215.90	1/8	3.18	4.1	1.9
870572100	CARE	2 1/4	57.15	2 15/16	74.61	9	228.60	3/32	2.38	3.1	1.4
870572133	CARD	2 1/4	57.15	3	76.20	9	228.60	1/8	3.18	3.9	1.8
870572101	CART	2 1/4	57.15	3 1/8	79.38	9	228.60	1/8	3.18	4.3	2.0
870572102	CASE	2 1/4	57.15	3 3/8	85.73	9	228.60	1/8	3.18	5.1	2.3
870602100	COOK	2 3/8	60.33	3 3/8	85.73	9 1/2	241.30	1/8	3.18	4.8	2.2
870642100	CORD	2 1/2	63.50	3 1/8	79.38	10	254.00	1/8	3.18	4.5	2.0
870642101	CORN	2 1/2	63.50	3 3/8	85.73	10	254.00	1/8	3.18	5.1	2.3
870642134	COVE	2 1/2	63.50	3 1/2	88.90	10	254.00	5/32	3.97	6.6	3.0
870672100	CRAB	2 5/8	66.68	3 3/8	85.73	10 1/2	266.70	1/8	3.18	5.2	2.4
870702100	CROW	2 3/4	69.85	3 3/8	85.73	11	279.40	1/8	3.18	4.8	2.2
870702139	CUBE	2 3/4	69.85	3 1/2	88.90	11	279.40	5/32	3.97	6.6	3.0
870702101	CURD	2 3/4	69.85	3 3/4	95.25	11	279.40	1/8	3.18	6.6	3.0
870732100	CURE	2 7/8	73.03	3 3/4	95.25	11 1/2	292.10	1/8	3.18	6.5	2.9
870762100	DANE	3	76.20	3 3/4	95.25	12	304.80	1/8	3.18	6.8	3.1
870762101	DARE	3	76.20	4	101.60	12	304.80	1/8	3.18	7.7	3.5
870802100	DARK	3 1/8	79.38	4 1/4	107.95	12 1/2	317.50	1/8	3.18	8.6	3.9
870832100	DARN	3 1/4	82.55	4	101.60	13	330.20	1/8	3.18	7.8	3.5
870832101	DELL	3 1/4	82.55	4 1/4	107.95	13	330.20	1/8	3.18	8.7	3.9
870862100	DIKE	3 3/8	85.73	4 1/2	114.30	13 1/2	342.90	1/8	3.18	10.2	4.6
870892100	DINE	3 1/2	88.90	4 1/4	107.95	14	355.60	1/8	3.18	8.9	4.0
870892101	DOCK	3 1/2	88.90	4 1/2	114.30	14	355.60	1/8	3.18	10.3	4.7
870922100	DOLE	3 5/8	92.08	4 1/2	114.30	14 1/2	368.30	1/8	3.18	10.0	4.5
870952100	DONE	3 3/4	95.25	4 1/2	114.30	15	381.00	1/8	3.18	9.6	4.4
870952101	DOVE	3 3/4	95.25	5	127.00	15	381.00	3/16	4.76	16.5	7.5
870952102	DRAW	3 3/4	95.25	5 1/4	133.35	15	381.00	3/16	4.76	18.2	8.3
870992100	DULL	3 7/8	98.43	5 1/4	133.35	15 1/2	393.70	3/16	4.76	18.7	8.5
871022100	EARN	4	101.60	5	127.00	16	406.40	3/16	4.76	16.9	7.7
871022101	EASE	4	101.60	5 1/4	133.35	16	406.40	3/16	4.76	18.7	8.5
871052100	ECHO	4 1/8	104.78	5 1/4	133.35	16 1/2	419.10	3/16	4.76	19.0	8.6
871082100	EDIT	4 1/4	107.95	5 1/2	139.70	17	431.80	3/16	4.76	22.0	10.0
871112100	ELSE	4 3/8	111.13	5 3/4	146.05	17 1/2	444.50	3/16	4.76	23.7	10.8
871152100	EPIC	4 1/2	114.30	5 1/2	139.70	18	457.20	3/16	4.76	21.3	9.7
871152101	EDGE	4 1/2	114.30	5 3/4	146.05	18	457.20	3/16	4.76	23.7	10.8
871182100	EVEN	4 5/8	117.48	6 1/8	155.58	18 1/2	469.90	1/4	6.35	42.0	19.1
871212100	EVER	4 3/4	120.65	6 1/8	155.58	19	482.60	1/4	6.35	41.0	18.6
871242100	EVIL	4 7/8	123.83	6 1/8	155.58	19 1/2	495.30	1/4	6.35	41.7	18.9
871272100	FACE	5	127.00	6 1/8	155.58	20	508.00	1/4	6.35	42.3	19.2
871272101	FACT	5	127.00	6 1/2	165.10	20	508.00	1/4	6.35	48.7	22.1
871342100	FADE	5 1/4	133.35	6 3/4	171.45	21	533.40	1/4	6.35	50.3	22.8
871342101	FARE	5 1/4	133.35	7	177.80	21	533.40	1/4	6.35	55.0	24.9
871372100	FEAR	5 3/8	136.53	6 3/4	171.45	21 1/2	546.10	1/4	6.35	51.3	23.3
871372101	FELT	5 3/8	136.53	7	177.80	21 1/2	546.10	1/4	6.35	56.0	25.4
871402100	FIND	5 1/2	139.70	7	177.80	22	558.80	1/4	6.35	56.0	25.4
871432100	FLAT	5 5/8	142.88	7	177.80	22 1/2	571.50	1/4	6.35	55.5	25.2
871462100	FORK	5 3/4	146.05	7	177.80	23	584.20	1/4	6.35	56.5	25.6
871502100	FUEL	5 7/8	149.23	7 1/2	190.50	24	609.60	1/4	6.35	65.8	29.8
871532100	GALE	6	152.40	7 1/2	190.50	24	609.60	1/4	6.35	66.0	29.9
871662100	GOLD	6 1/2	165.10	8 3/8	212.73	30	762.00	7/16	11.11	150.0	68.0

All Bearings Shown Are Carried in Stock

Naval Brass Sleeve Bearings

METRIC SIZE SERIES



Johnson Cutless® Naval Brass Sleeve Bearings adapt equally well to strut and stern-tube mounts, and are often used effectively as rudder-stock and pintle bushings. Bearing diameters are precision fitted to the designated shaft size with the correct clearance for efficient water lubrication. External brass shells are machined and polished to provide easy fitting. Specially formulated oil and chemical resistant nitrile rubber is securely bonded to the shell. Units with thin shells are available for the struts of small craft. Sleeve Bearings are usually installed by light press-fitting and locked in place with cone-pointed set screws.

PRECAUTION:

When shrink fitting of the bearing is required, chilling must be achieved by gradual cooling to not more than minus 20°F(-28°C) using freezer or regular ice (**DO NOT DRY ICE**). NOTE: Pounding or shocking the bearing while in the chilled state could cause the rubber to separate from the shell.

Approved Bearings: Johnson Cutless® Naval Brass Sleeve Bearings meet military specification MIL-B-17901 (Ships) Class II Full-Molded type and have full type approval from The American Bureau of Shipping.

NAVAL BRASS SLEEVE - METRIC

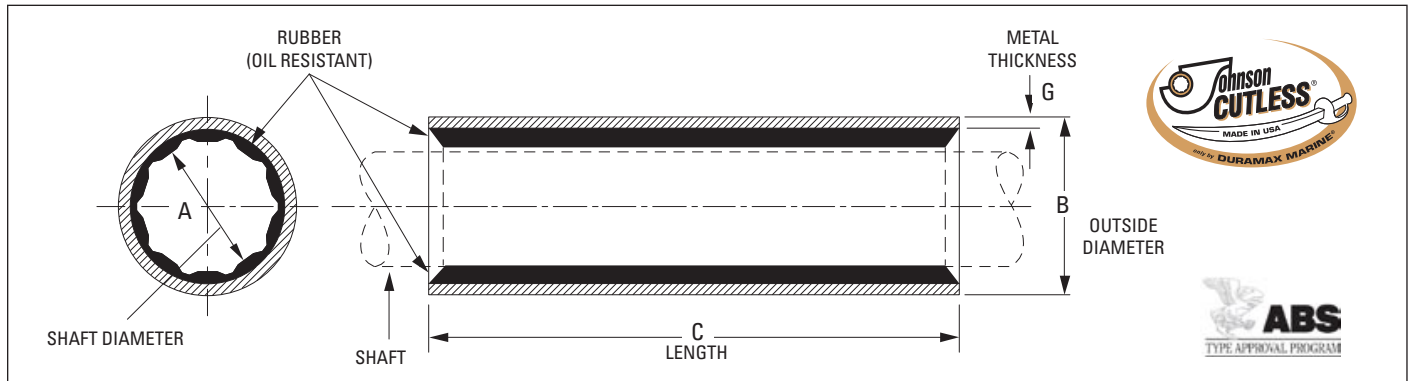

Part Number	A Shaft Diameter mm	B Outside Diameter mm	C Length mm	G Metal Thickness mm	Gross Wt.	
					lb.	kg.
870254100	25	40	100	2.54	0.8	0.4
870284100	28	42	112	2.35	0.7	0.3
870304100	30	45	120	3.07	1.2	0.5
870324100	32	45	128	3.07	1.3	0.6
870354100	35	50	140	3.07	1.5	0.7
870384100	38	55	152	3.07	1.7	0.8
870404100	40	55	160	3.07	1.8	0.8
870454100	45	65	180	3.30	2.8	1.3
870504100	50	70	200	3.26	3.1	1.4
870554100	55	75	220	2.58	3.8	1.7
870604100	60	80	240	3.26	4.5	2.0
870654100	65	85	260	2.82	4.8	2.2
870704100	70	90	280	4.76	5.8	2.6
870754100	75	95	300	3.05	6.7	3.0
870804100	80	100	320	3.17	7.7	3.5
870854100	85	105	340	3.19	8.7	3.9
870904100	90	110	360	4.78	12.5	5.7
870954100	95	115	380	4.51	13.3	6.0
871004100	100	125	400	3.77	14.3	6.5
871054100	105	130	420	4.52	17.6	8.0
871104100	110	135	440	4.51	19.0	8.6
871154100	115	145	460	4.25	25.3	11.0
871204100	120	155	480	6.06	31.6	14.0
871304100	130	170	520	5.63	49.0	22.0
871404100	140	180	560	7.45	56.0	25.0